

EN

General Catalog

Sprue Picker/Linear Robots

Prime Series

Controller	Drive	Power supply	Positioning repeatability
CNC	Brushless synchronous with drive on board	220 Volt.	± 0,1 mm



Prime series

Robot distinguished by high accuracy, smooth movement and repeatability of positioning, thanks to the Servo motors (controlled via digital signals) and the strong mechanics. The robot control unit belongs to the PRIME series and is located on board, in a way not to cause obstruction on the ground.

The User interface is characterised by a portable ergonomic console manufactured in carbon fibre to minimise weight and maximise strength; it is connected by a 5 m cable. It has a 4.3" graphical colour display with knob for browsing the menus, keys dedicated to direct movement of the axes, safety button and operator presence button.

Furthermore, the presence of a USB port allows copying, exporting and importing of the "work files" and the "set-ups" on computer or other robots.

The programming system is based on a series of simple and intuitive "ready to use" functions and does not require any specific knowledge regarding management of automatic machines. The work cycle is created by entering the various functions that the robot is to perform. This allows the establishment staff to optimise and adapt the production cycles, which can then be protected by password to prevent involuntary or inappropriate tampering.

Standard, ready to use work cycles are also available.

The main functions performed:

- Axes positioning with individual or simultaneous movements
- Couplings between movements for higher speed and smoothness of trajectories
- Performance of the work cycle in step-by-step mode, both forward and reverse
- Self-learning of positions
- Free programming of 200 steps
- Robot switch on cycle and axes reset programmable freely and can be archived for each program
- 4 Palletising layouts, which can be changed from one program to another, combined within the same program and archived with each of these.
- Introduction of layers in pallets
- Mechanical grippers management
- Vacuum lines management
- Conveyor belt command
- IMM interface management with "macro" functions, which simplify sending commands to and from the IMM.
- External Input/Output management (external machine commands and/or accessories such as shears, labelling devices, etc...)
- "IF" and "wait" functions for conditioned performance of parts of the program
- "Search" function on axes movement
- Status display of Input, output and any alarms
- Manual movement of electric axes, grippers, suction pads, programmable outputs
- IMM tie-bars clearance management, to prevent collisions in the event of incorrect programming



E-Series EVO

Controller	Drive	Power supply	Positioning repeatability
CNC	Brushless synchronous with drive on board	220 Volt.	± 0,1 mm

X-Series EVO

Controller	Drive	Power supply	Positioning repeatability
CNC	Brushless synchronous	380 Volt.	± 0,1 mm



The control unit of E SERIES EVO and X SERIES EVO series robots is governed by a CNC installed with a professional operating system that enables applications in real-time and multi-tasking functions to manage operations that run parallel to the movements of the robot. The interface between control and drive is fully digital and provides excellent axes operating performance. The position signals (setpoint and feedback) travel on CANBus allowing the control unit to receive and manage the information concerning the position of each axis in just a fraction of a second.

In this series, machine programming is carried out entirely through the portable control console, with a colour TFT high resolution display screen. For limited-sized robots up to model MC3, the panel is located on board the machine, without occupying space on the ground. For technical reasons however, the large-sized models (MC4, MC5, MC6) and side entry robots (model SM2) have their control units on the ground, though they are equipped with a portable console with a colour TFT display screen.

The panel has 3 actuators, one for each of the three axes, for brushless synchronous motors operated by a CNC; this solution, combined with the use of enhanced motors and the use of a vertical S / H-type axis, enables very fast work cycles.

Standard functions available:

- The programming system allows free working cycles to be created, through functions that perform the following
- axes positioning with linear interpolation movement;
- extraction assisted with the electronic control of the X-axis engine torque by following the movement of the press extractor;
- execution of movements at different speeds compared to the set speed for the cycle;
- synchronization of the robot cycle with the press cycle time;
- opening and closing of mechanical grippers (standard valve base designed for a total of 6 suckers and grippers + optional expansion kit mounted on the wrist for an additional 4 or 8 grippers);
- separate management of max. 6 vacuum lines each with its own release mechanism and monitoring sensor;
- possibility to manage up to 4 analogic vacuum sensors
- dynamic vacuum to reduce the air consumption
- wrists rotations;
- IMM interface management (Euromap 12 or 67);
- HSI (High speed interface) functionality for IMM management
- deposit belt control;
- cutter control;
- external labelling machine control;
- palletizing (possibility of managing up to 10 palletizing patterns);
- depalletizing also possible with "search" movements;
- reject piece management;
- piece management for quality control;
- lining pallets with cardboard sheets;
- EASY PROGRAMMING: graphical programming - a basic PICK 'n PLACE programme is immediately generated in 4 steps in a Wizard mode. Images and animations help the user to choose the right options value;
- GRAPHIC EDITOR: program edit is possible using a graphic editor with FLAGS, images and animations;
- MULTI-USER: ability to define users with personal password and custom level of permissions
- Off-line programming: software that is installed on a PC and reproduces the operator's interface, allowing the work cycle to be programmed off-line;
- a library of programming functions at your disposal for the creation of basic cycles, which can be modified by the operator;
- storage of programs, without a limit to the number of programs, thanks to an external USB memory;
- Assistance from CAMPETELLA SERVICE: through an USB key it is possible to download and send information relevant to the problem via the Internet.
- A portable TOUCH teach box, with high resolution colour 7" TFT display, enables the robot complete programming.



Sprue Picker

SP3R Prime



IMM(Ton)	Model	Vertical	A axis	B axis	X axis(mm)	Y axis(mm)	Load(Kg)	Dry Cycle
20-300	SP3R	-	±90°	0-90°	300	800	up to 1	from 4''

SP3R model, fully made in profile aluminum, is recommended for IMM from 20 to 300 Ton. its peculiarity consists in the 3-axis electric servo controlled, including the axis A with rotation from 0 to 90

SP3R-AR Prime



IMM(Ton)	Model	A axis	B axis	X axis(mm)	Y axis(mm)	Rotation	Load(Kg)	Dry Cycle
20-300	SP3R-AR	±90°	0-90°	300	800	0-46-60°	up to 1	from 4''

SP3R-AR model, fully made in profile aluminum, is recommended for IMM from 20 to 300 Ton. its peculiarity consists in the 3-axis electric servo controlled, including the axis A with rotation from 0 to 90 degrees and a pneumatic rotary base adjustable from 0 to 45 to 60 degrees.

SP3C Prime



IMM(Ton)	Model	Vertical	Z Axis (mm)	X Axis (mm)	Y Axis (mm)	Load(Kg)	Dry Cycle
20-150	SP3C	A	1200-1500	300	800	up to 1	from 4''

SP3C-mini model, fully made in profile aluminum, is recommended for IMM from 20 to 150 Ton. its peculiarity consists in the Y axes (vertical) integrated with the X axis (ex- traction)

Linear Robots

Rhea Prime



IMM(Ton)	Model	Vertical	Z Axis (mm)	X Axis (mm)	Y Axis (mm)	Load(Kg)	Dry Cycle
20-150	RHEA	A	1200-1500	300	800	up to 2	from 5''

Rhea is the smallest of Campetella's Linear robots, born for IMMs from 20 to 150 tonnes, has three servo-controlled electric axes.

Rhea is equipped with the new Prime Series controller and is designed for multicurrency take-out.

CX Prime

IMM(Ton)	Model	Vertical	ZAxis (mm)	XAxis (mm)	Y Axis (mm)	Load(Kg)	Dry Cycle
20-200	CXI	A	1500-2000	600	1200	up to 6	from 6''



CX model, fully made in profile aluminum, is recommended for small tonnage IMMs; X axis (extraction) is fixed on the Z-axis cart with no obstruction on the hopper side of the IMM.

CX E-Series

IMM(Ton)	Model	Vertical	ZAxis (mm)	XAxis (mm)	Y Axis (mm)	Load(Kg)	Dry Cycle
20-200	CXI	A	1500-2000	600	1200	up to 6	from 5,5''



CX model, fully made in profile aluminum, is recommended for small tonnage IMMs; X axis (extraction) is fixed on the Z-axis cart with no obstruction on the hopper side of the IMM.

ME Prime

IMM(Ton)	Model	Vertical	ZAxis (mm)	XAxis (mm)	Y Axis (mm)	Load(Kg)	Dry Cycle
20-200	MEI	A	1500-2000	600	1200	up to 6	from 6''



ME model, fully made in profile aluminum, is recommended for small tonnage IMMs; its unique feature consists in having Y-axis (vertical) that is integral with the X-axis (extraction).

ME E-Series

IMM(Ton)	Model	Vertical	ZAxis (mm)	XAxis (mm)	Y Axis (mm)	Load(Kg)	Dry Cycle
20-200	MEI	A	1500-2000	600	1200	up to 6	from 5,5''



ME model, fully made in profile aluminum, is recommended for small tonnage IMMs; its unique feature consists in having Y-axis (vertical) that is integral with the X-axis (extraction).

Linear Robots

CL X-Series



IMM(Ton)	Model	Vertical	ZAxis (mm)	XAxis (mm)	Y Axis (mm)	Load(Kg)	Dry Cycle
Up to 600	CL2	H	2000-2500	1000	1600	up to 18	from 5"
Up to 600	CL2	M	2000-2500	1000	1200	up to 25	from 7"
Up to 600	CL2	B	2000-2500	1000	1400	up to 16	from 5"

CL model is recommended for small and medium tonnage IMMs; X-axis (extraction) remains fixed on the Z-axis cart with no obstruction on the hopper-side of the IMM.

CL E-Series



IMM(Ton)	Model	Vertical	ZAxis (mm)	XAxis (mm)	Y Axis (mm)	Load(Kg)	Dry Cycle
Up to 600	CL2	A	2000-2500-3000	1000	1400	up to 9	From 10"
Up to 600	CL2	L	2000-2500-3000	1000	1600	up to 9	From 10"

CL model is recommended for small and medium tonnage IMMs; X-axis (extraction) remains fixed on the Z-axis cart with no obstruction on the hopper-side of the IMM.

CO X-Series



IMM(Ton)	Model	Vertical	ZAxis (mm)	XAxis (mm)	Y Axis (mm)	Load(Kg)	Dry Cycle
Up to 200	CO1-I	S	1600	600	1000	up to 9	From 4"
Up to 400	CO2-I	S	2000-2500	700	1400	up to 9	From 5"

CO model is recommended for small and medium tonnage IMMs; X-axis (extraction) remains fixed on the Z-axis cart with no obstruction on the hopper-side of the IMM.

CO E-Series



IMM(Ton)	Model	Vertical	ZAxis (mm)	XAxis (mm)	Y Axis (mm)	Load(Kg)	Dry Cycle
Up to 200	CO1	A - L	1600	600	1000	up to 9	From 7"
Up to 400	CO2	A	2000-2500	700	1200	up to 9	From 9"
Up to 400	CO2	L	2000-2500	700	1400	up to 9	From 9"

CO model is recommended for small and medium tonnage IMMs; X-axis (extraction) remains fixed on the Z-axis cart with no obstruction on the hopper-side of the IMM.

MC X-Series



MC model is recommended for medium and large tonnage IMMs; its unique feature consists in having Y-axis (vertical) that is integral with the X-axis (extraction).

IMM(Ton)	Model	Vertical	ZAxis (mm)	XAxis (mm)	Y Axis (mm)	Load(Kg)	Dry Cycle
Up to 600	MC2	H	2000-2500-3000	1000	1600	up to 18	From 5"
Up to 600	MC2	M	2000-2500-3000	1000	1200	up to 25	From 8"
Up to 600	MC2	B	2000-2500-3000	1000	1400	up to 16	From 7"
Up to 1000	MC3	H	2500-3000-3500	1200	1800	up to 30	From 7"
Up to 1000	MC3	B	2500-3000-3500	1200	1600	up to 30	From 7"
Up to 1600	MC4	H	3000-3500-4000	1500	2400	up to 40	From 10"
Up to 1600	MC4	T	3000-3500-4000	1500	2580	up to 25	From 15"
Up to 3000	MC5	H	4000-5000	2000	2400-2800	up to 60	From 25"
Up to 3000	MC5	T	4000-5000	2500	2400-2800	up to 40	From 25"
Up to 6000	MC6	H	6000	2500	3400	up to 120	From 40"
Up to 6000	MC6	T	6000	2500	3400	up to 80	From 40"

MC E-Series

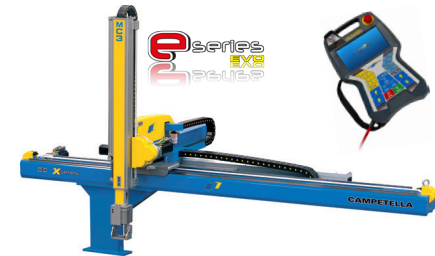

IMM(Ton)	Model	Vertical	ZAxis (mm)	XAxis (mm)	Y Axis (mm)	Load(Kg)	Dry Cycle
Up to 600	MC2	A	2000-2500-3000	1000	1400	up to 9	From 10"
Up to 600	MC2	L	2000-2500-3000	1000	1600	up to 9	From 10"
Up to 1000	MC3	L	2500-3000-3500	1200	1800	up to 16	From 12"

MC model is recommended for medium and large tonnage IMMs; its unique feature consists in having Y-axis (vertical) that is integral with the X-axis (extraction).

LD X-Series



Mechanical type LD perfectly incorporated side overall size of the IMM, the Z-axis lengths up to 10 meters and vertical axes of mono-extension, telescopic extension triple allow us to configure the right solution for any model and size of horizontal injection molding machine.

IMM(Ton)	Model	Vertical	ZAxis (mm)	XAxis (mm)	Y Axis (mm)	Load(Kg)	Dry Cycle
Up to 600	LD2	H	5000-6000-7000	1000	1600	up to 18	From 10"
Up to 600	LD2	B	5000-6000-7000	1000	1200	up to 16	From 10"
Up to 1000	LD3	H	6000-7000-8000	1000	1800	up to 30	From 12"
Up to 1000	LD3	T	6000-7000-8000	1000	2800	up to 15	From 12"
Up to 1600	LD4	H	7000-8000-9000	1200	2000-2400	up to 40	From 15"
Up to 1600	LD4	T	7000-8000-9000	1200	2000-2580	up to 25	From 15"

LD E-Series



Mechanical type LD perfectly incorporated side overall size of the IMM, the Z-axis lengths up to 10 meters and vertical axes of mono-extension, telescopic extension triple allow us to configure the right solution for any model and size of horizontal injection molding machine.

IMM(Ton)	Model	Vertical	ZAxis (mm)	XAxis (mm)	Y Axis (mm)	Load(Kg)	Dry Cycle
Up to 600	LD2	A	5000-6000-7000	1000	1400	up to 9	From 15"
Up to 600	LD2	L	5000-6000-7000	1000	1600	up to 9	From 15"
Up to 1000	LD3	A	6000-7000	1000	1600	up to 16	From 18"
Up to 1000	LD3	L	6000-7000	1000	1800	up to 16	From 18"

Linear Robots

GS2 X-Series



IMM(Ton)	Model	Vertical	Z Axis (mm)	X Axis (mm)	Y Axis (mm)	Load(Kg)	Dry Cycle
up to 400	GS2	B	2000-2500	600	1000-1200	up to 2,5	from 2,3"

Gunshot, the new linear robot, born to meet high speed moulding needs, operating cycle times of 2,3 seconds.

CL2W X-Series



IMM(Ton)	Model	Vertical	Z Axis (mm)	X Axis (mm)	Y Axis (mm)	Load(Kg)	Dry Cycle
up to 600	CL2W	A	2000-2500-3000	2x700	2x1400	up to 2x6	from 6"
up to 600	CL2W	H	2000-2500-3000	2x700	2x1600	up to 2x18	from 8"

Double robot for IMMs with double or sandwich mold, 5 axes interpolation with 2 vertical axes mounted on a single extraction axis, each vertical axis having its own independent motor

SPIN X-Series



Model	Arms length	Z axis(mm)	Load(Kg)
SPIN-1000	550+450	500	up to 10
SPIN-1200	650+550	900-3300	up to 50
SPIN-1500	800+700	900-3300	up to 50

X-Series SPIN, the new Scara robot completely developed in Campetella, could replace 6 axes robot for stacks management

SM2 X-Series



IMM(Ton)	Model	Vertical	Z Axis (mm)	X Axis (mm)	Y Axis (mm)	Load(Kg)	Dry Cycle
up to 600	SM2	O	1800	600	700	up to 12	from 4"
up to 600	SM2	Stack	2x1800	2x600	2x700	up to 2x12	from 4"

SM model (Side Machine) for lateral unloading, is recommended for particularly fast work cycles with or without IML and possibility to work on STACK MOLD (Sandwich)

SM3 X-Series



IMM(Ton)	Model	Vertical	Z Axis (mm)	X Axis (mm)	Y Axis (mm)	Load(Kg)	Dry Cycle
up to 800	SM3	O	2000	800	800	up to 24	from 6"
up to 800	SM3	D	2x2000	800	800	up to 2x12	from 6"

SM model (Side Machine) for lateral unloading, is recommended for particularly fast work cycles with or without IML and possibility to work on STACK MOLD (Sandwich)

Concept X-Series



IMM(Ton)	Model	Vertical	Z Axis (mm)	X Axis (mm)	Y Axis (mm)	Load(Kg)	Dry Cycle
up to 500	Concept-1	-	2100	100	650	up to 8	from 3"
up to 500	Concept-2	-	2500	150	650	up to 12	from 4"

Robot 3 axes for lateral download of high speed IMM. Dedicated for IMM of molding of plastics, suitable for the discharge of very light items, with a high number of cavities in the mold, and for extremely short cycle times.

Modula X-Series



IMM(Ton)	Model	Vertical	Z Axis (mm)	Pliers(mm)	Discharge(mm)	Load(Kg)	Dry Cycle
up to 600	Modula	-	2000 - 2500	300	650	-	from 4,5"
up to 800	Modula Maxi	-	2500 - 3000	400	650	-	from 6"

MODULA model for lateral unloading, is especially dedicated to the implementation of IML plants (In Mould Labeling), for STACKMOLDING (Sandwich) and other special applications.

Modula X-Series

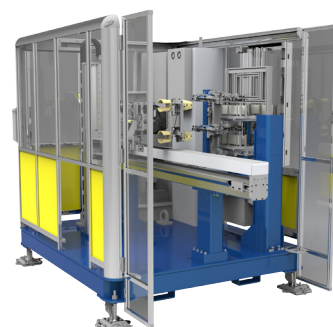

IMM(Ton)	Model	Vertical	Z Axis (mm)	Pliers(mm)	Discharge(mm)	Load(Kg)	Dry Cycle
up to 600	Modula Mini	-	2000-2500	150	650	-	from 2,5"

MODULA MINI model for lateral unloading, is especially dedicated to the implementation of IML plants (In Mould Labeling), for STACKMOLDING (Sandwich) and other special applications.

Electrical panel position/Vertical Axis

Electrical panel on the ground

Electrical panel on the ground for model MC4, MC5, MC6, GS2, LD, SM2, SM3.

Electrical panel on the ground only on X series models CO1, CO2, CX2, CL2W, MC2, MC3.



Electrical panel on board

Electrical panel on board for model ME1, CX1, CO1, CO2, CX2, CL2W, MC2, MC3, Concept, Mini Modula, Modula, Modula Maxi.



Vertical axis A (Sprue Piker+REHA)

The vertical axis type A single stroke with sliding on bearings on profile, is the cheapest model now available for the Skill. Without cylinder balancing.



Prime
series

Balance
X

Stroke
1

Guides
2

Vertical axis A (CX-ME)

The vertical axis type A single stroke with sliding on bearings on profile, is the cheapest model now available for the Skill. Without cylinder balancing.

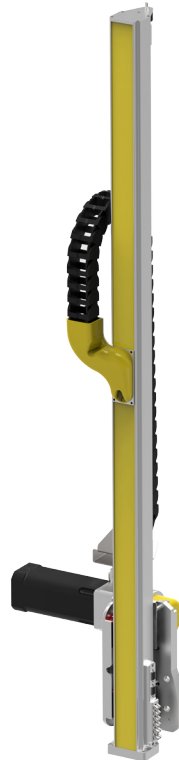

Prime
series
eseries
LVC

Balance
X

Stroke
1

Bearings
2

Vertical axis A (E-Series)



The vertical axis type A single stroke and single guide, is the cheapest model now available for the E-series. Without cylinder balancing.



Balance	Stroke	Guides
X	2	1

Vertical axis L (E-Series)

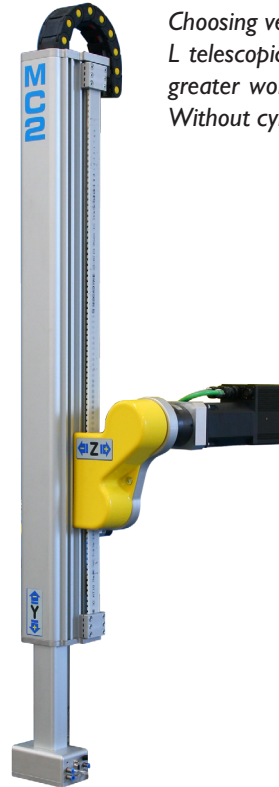

Choosing version E-Series with the vertical axis type L telescopic, with single prismatic guide, you get a greater working stroke, a lower vertical dimension. Without cylinder balancing.



Balance	Stroke	Guides
X	2	1

Vertical axis B



The vertical axis type B single stroke with double prismatic guide, determines for the X-Series, an economical choice. The B-type carbon axis is available only for models GS2 Gunshot



Balance	Stroke	Guides
X	1	2

Vertical axis M

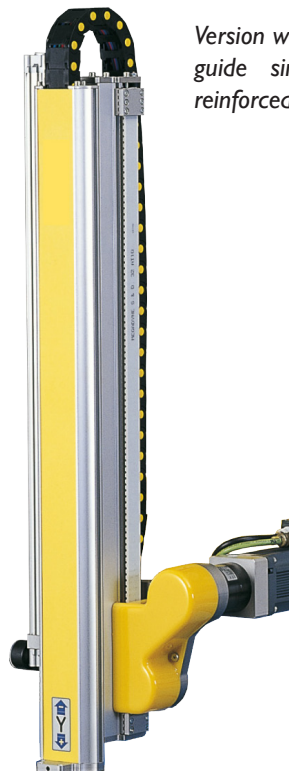

Version with increased capacity and rigidity, double-guide single-stroke with pneumatic balancing, reinforced wrist



Balance	Stroke	Guides
✓	1	2

Vertical Axis

Vertical axis H



Choosing the version X-Series with the vertical axis type H telescopic, with double prismatic guide, you get a greater working stroke, a lower vertical dimension, and you can take advantage of the pneumatic balancing

Xseries
EVO

Balance
✓

Stroke
2

Guides
2

Vertical axis S(E-Series)

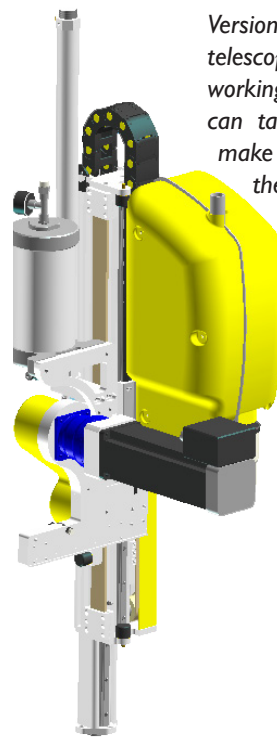

Version E-Series adopts the vertical axis type S telescopic single prismatic guide, you get a greater working stroke, a lower vertical dimension, and you can take advantage of pneumatic balancing. To make the deposit on the flat of the molded pieces, the pneumatic C axis is mounted, with which you can choose to program between two positions (vertical / horizontal).

Eseries
EVO

Balance
✓

Stroke
2

Guides
1

Vertical axis S (X-Series)



Xseries
EVO

Balance
✓

Stroke
2

Guides
1

Vertical axis T



The vertical axis type T is a telescopic triple stroke with pneumatic balancing, is targeted to applications that require reduced dimension due to the space available or to the presence of low overhead crane. To make the deposit on the flat of the molded pieces, the pneumatic C axis is mounted at 108Nm, with which you can choose to program between two positions (vertical / horizontal).

Xseries
EVO

Balance
✓

Stroke
3

Guides
2

O Axis

The vertical axis type O double stroke and double guide.



Xseries
EVO

Balance



Stroke

2

Guides

2

D Axis

The vertical axis type D consists in two double axes, double stroke and double guide

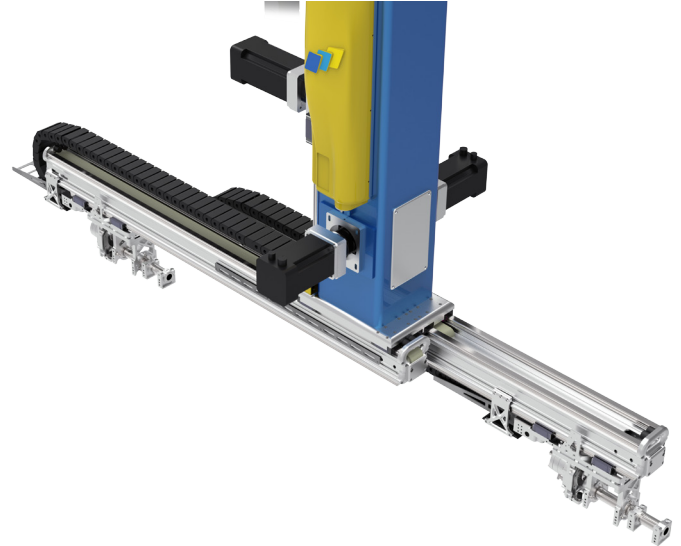

Xseries
EVO

Balance



Stroke

2

Guides

2

STACK Axis

The vertical axis Stack is composed of two groups Y-Z separated, each with dual-axis stroke and double guide.

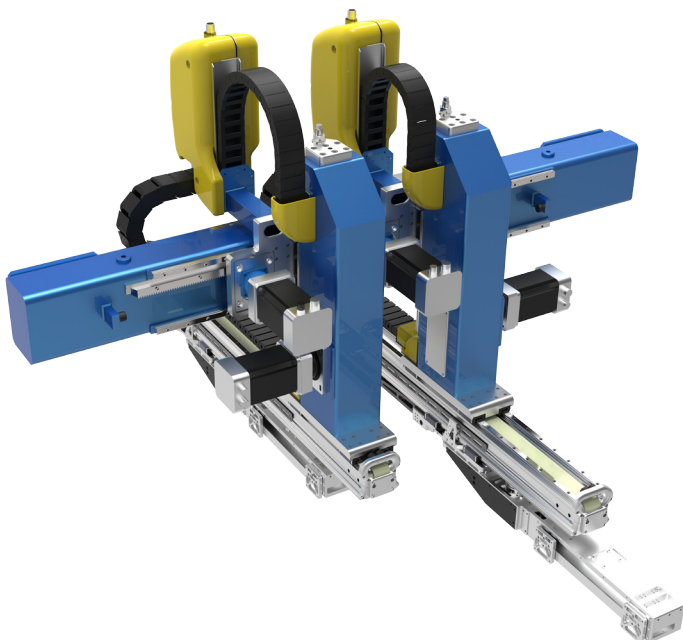

Xseries
EVO

Balance



Stroke

2

Guides

2

Sprue Picker wrist

Pneumatic B axis

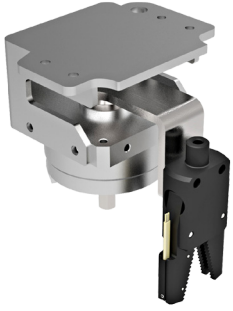

The B pneumatic axis, can be added when both have the need to rotate the wrist on itself in different positions, both in the case of palletization, or simply choose from program the side of the mold on which to intervene.

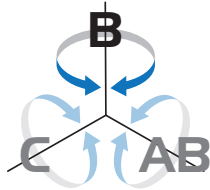
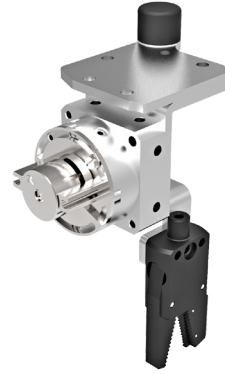

Photo: Pneumatic axis B

Pneumatic C axis



The C pneumatic axis facilitates the deposit in plan of the molded pieces picked up from the mold, choosing from the program between two positions (vertical/horizontal).

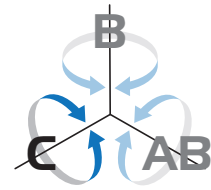

Photo: Pneumatic axis C

Linear Robots wrist

Pneumatic C axis (REHA)



The C pneumatic axis facilitates the deposit in plan of the molded pieces picked up from the mold, choosing from the program between two positions (vertical/horizontal).

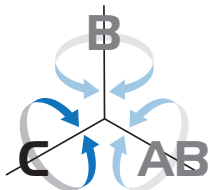

Photo: Pneumatic axis C

Pneumatic C axis

The C pneumatic axis facilitates the deposit in plan of the molded pieces picked up from the mold, choosing from the program between two positions (vertical/horizontal). There are three sizes: with a torque of 27Nm matching the vertical type A and L, of 57Nm matching the vertical type B and H and 77Nm combined with the vertical type M. It is possible to rotate the wrist manually 180° to select the side of the mold on which to intervene.

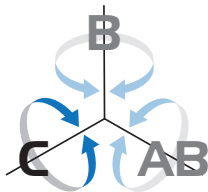

Photo: Pneumatic axis C, manual axis B

Pneumatic AB axis

For applications that require it, it is possible to choose the wrist with the additional pneumatic axis AB, which allows the rotation on its axis of the end of tool arm by choosing from the program between two positions mechanically fixed on the 0° -90° or 0° -180°. It is possible to rotate the wrist manually of 180° to choose the side of the mold on which to intervene.



Photo: Pneumatic axis C, manual axis B, pneumatic axis AB

Electrical B axis

The B interpolated electrical axis, can be added when both have the need to rotate the wrist on itself in different positions, both in the case of palletization, or simply choose from program the side of the mold on which to intervene.

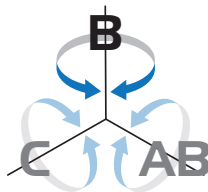

Photo: Pneumatic axis C, electric axis B

C and AB electrical axis

For the most demanding applications made with the X-Series, you can choose the wrist axes C and AB Electric, making the robot a machine with 5 interpolated axes. The realization with brushless servomotors and reducers Harmonic drive allows fast and precise movements. The axis AB has the ability to rotate even for more laps, while the axis C with its maximum rotation of 180°, allows you to choose from the program side of the mold on which to intervene.

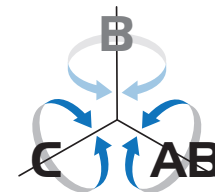

Photo: Electric axis C, Manual axis B, electric axis AB

General Catalog



Campetella Robotic Center Srl

Via Grazia Deledda, 40/42 - 62010 Montecassiano (MC) - Italy

Tel. (+39) 0733 29891 - Fax. (+39) 0733 298912

www.campetella.com - commerciale@campetella.it

